

# Type 100 Cross Sectional and Part Description

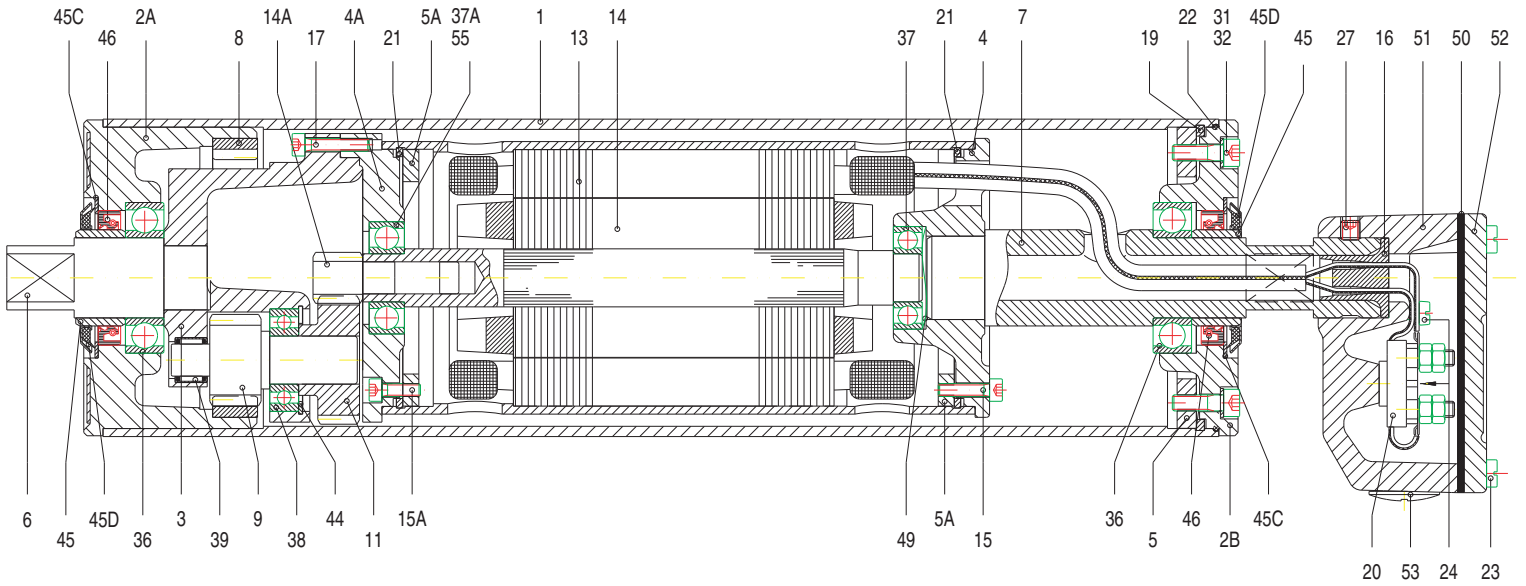

Position No.	Part Description	Position No.	Part Description
1	Shell	22	O-Ring
2A	End Flange	23	Fillister Head Machine Screw
2B	End Flange	24	Fillister Head Machine Screw
3	Gear Housing	27	Set Screw
4	Motor Flange	31	Socket Head Cap Screw
4A	Motor Flange	32	Washer Copper
5	Mounting Ring	36	Ball Bearing
5A	Mounting Ring	37	Ball Bearing
6	Shaft End	37A	Ball Bearing
7	Hollow Shaft	38	Ball Bearing
8	Internal Gear	39	Needle Bearing
9	Pinion	44	Snap Ring
11	Gear	45	Bearing Race
13	Stator	45C	Shim Plate
14	Rotor	45D	Gamma Ring
14A	Insert pinion	46	Oil Seal
15	Socket Head Cap Screw	49	Wave Washer
15A	Socket Head Cap Screw	50	Seal
16	Cable Passage	51	Junction Box
17	Socket Head Cap Screw	52	Junction Box Cover
19	Spring Ring	53	Plug
20	Terminal Board	55	Backstop Bearing
21	Spring Ring	57	Name Plate