

Type 400 Cross Sectional and Part Description

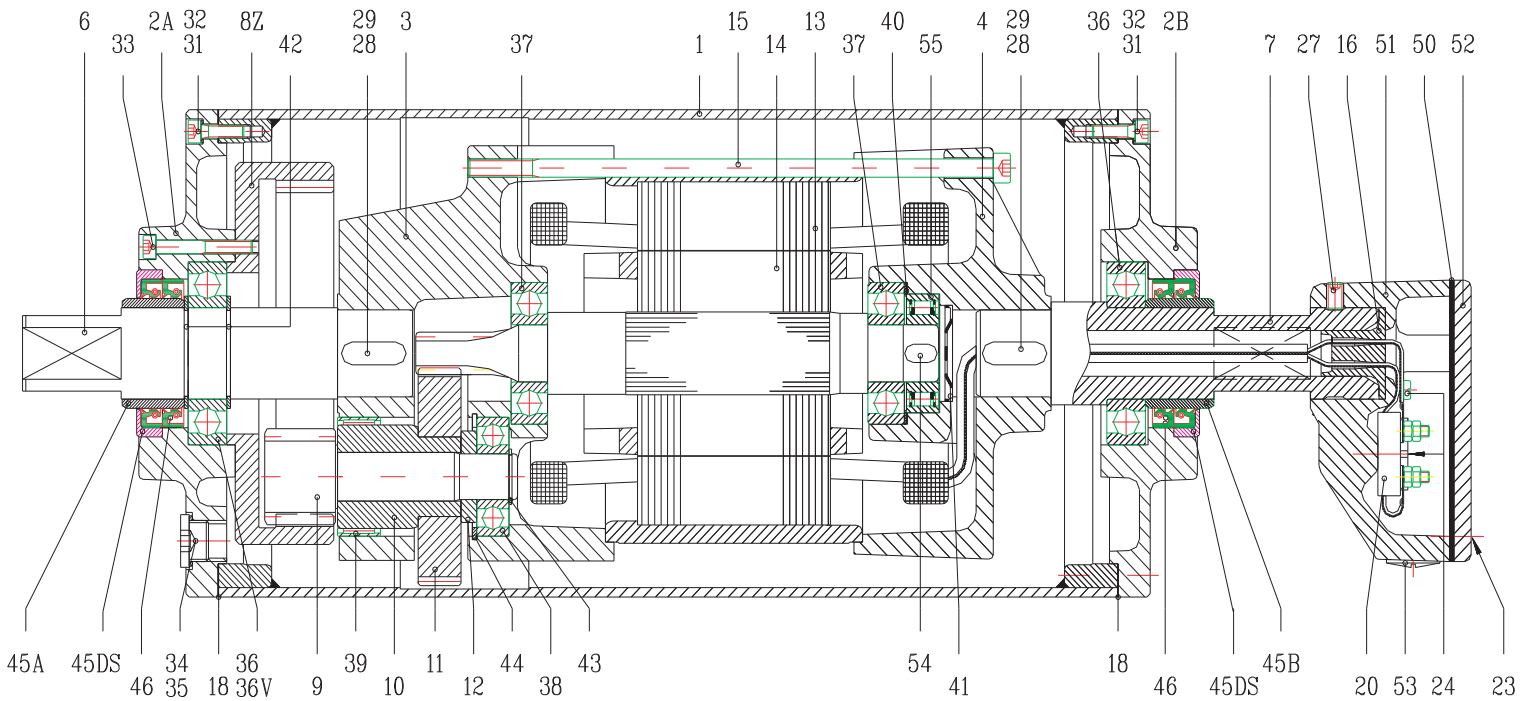

Position No.	Part Description	Position No.	Part Description
1	Shell	33	Socket Head Cap Screw
2A	End Flange	34	Filler Plug
2B	End Flange	35	Washer
3	Gear Housing	36	Ball Bearing
4	Motor Flange	36V	Cylindrical Bearing
6	Shaft End	37	Ball Bearing
7	Hollow Shaft	38	Ball Bearing
8	External Gear	39	Needle Bearing
9/10	Pinion with Bushing	40	Shim
11	Gear	41	Locking Disc
12	Distance Ring	42	Snap Ring
13	Stator	43	Snap Ring
14	Rotor	44	Snap Ring
15	Socket Head Cap Screw	45A	Bearing Race
16	Cable Passage	45B	Bearing Race
18	Gasket	45DS	Double Seal Adaptor
20	Terminal Board	46	Oil Seal
23	Fillister Head Machine Screw	50	Seal
24	Fillister Head Machine Screw	51	Junction Box
27	Set Screw	52	Junction Box Cover
28	Set Screw	53	Plug
29	Key	54	Key
31	Socket Head Cap Screw	55	Backstop Bearing
32	Washer Copper	57	Name Plate